

4/2, 4/3 WAY DIRECTIONAL VALVE KV-5KO

- NG 6
- Up to 350 bar [5 076 PSI]
- Up to 75 L/min [19.8 GPM]
- Connection diagram and connecting dimensions to ISO 4401.
- Plug-in connector for solenoids to ISO 4400.
- 5-chamber model with good spool guidance.
- Optimized flow paths for low losses of pressure.
- Adjustment of the switching time.
- Wet pin solenoid with interchangeable coil.
- Manual emergency control.
- Protection of solenoid IP 65 to EN 60529 / IEC 60529.
- Fulfil EMC (89/336/EEC).



KV-4/3-5KO-6

Operation

Directional valves type KV with direct solenoid operation control the direction of the hydraulic medium flow.

These directional valves consist of a housing (1), a control spool (3), and one solenoid (2) with two return springs (4) in 4/2-way directional valves, and two solenoids (2) with two return springs (4) in 4/3-way directional valves. In 4/3-way directional valves the centre position of the control spool is the neutral position. The change-over to the operating position (a) and (b) is done by energizing the solenoids (2) "a" and "b" respectively, whereby the solenoid plunger acts on the control spool (3) via the operating pin (5), thus clearing the corresponding flow ways and establishing relevant links between ports A, B, P, and T.

When the solenoid (2) is de-energized, the control spool (3) is returned to its neutral position by the return spring (4). The change-over can be done manually by pressing the emergency manual override (6).

KV-4/2-5KO-6-81

Directional valve with two operating position, two solenoids without springs allow the control spool to be held in the operating position (detent). The control spool remains in the operation position also when the solenoids are de-energized.

Hydraulic symbols

Spool types

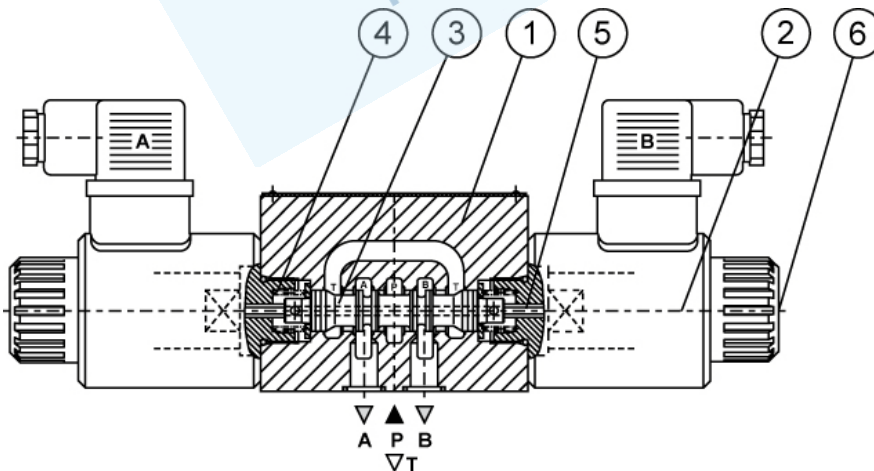
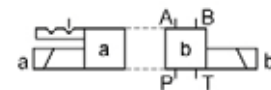
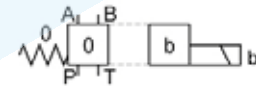
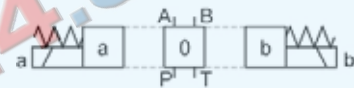



Features

Hydraulic			
Size	6		
Flow rate		L/min [GPM]	see ΔP-Q curves
Operating pressure	Ports A, B, P	bar [PSI]	350 [5 076]
	Port T	bar [PSI]	250 [3 625]
Viscosity range		mm ² /s [SUS]	15 to 380 [69.5 to 1 760]
Oil temperature range		°C [°F]	-20 to +70[-4 to 158]
Filtration		NAS 1638	8
Mass	4/2	Kg [lb]	1,9 [4.2]
	4/3		2,7 [5.9]
Mounting position	Optional		

Electrical			
Supply voltage	Direct	V	12, 24, 48
	Alternating		110, 230
Power		W	29*
Switch-on time**		ms	50 to 80
Switch-off time**		ms	30 to 55
Switching frequency		1/h	15 000
Ambient temperature		°C [°F]	to 50 [122]
Coil temperature		°C [°F]	to 180 [356]
Duty cycle	Continuous		

* 12 V supply voltage - 36 W.

** The switching-on and off times apply to 24 V DC solenoids.

ΔP-Q Performance curves

ΔP-Q Operating limits

Measured at 50°C [122°F] and viscosity of 32 mm²/s [148 SUS].

Measured at 50°C [122°F] and viscosity of 32 mm²/s [148 SUS].

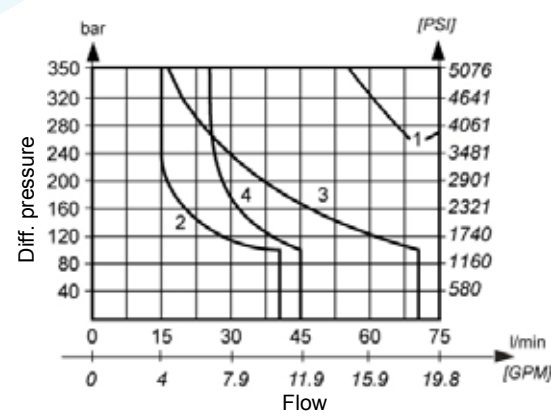
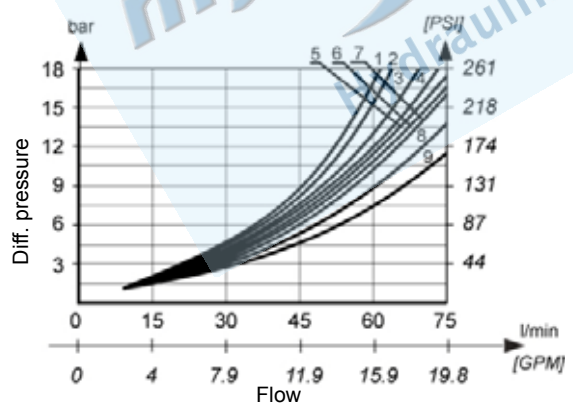

Spool	Flow path				
	P-A	P-B	A-T	B-T	P-T
1	8	8	6	6	-
2	5	5	4	4	1
3	8	8	7	7	-
6	5	5	9	9	-
81	5	5	1	1	-
51A, 51B	5	5	1	1	-
41A, 41B	7	7	-	-	-

Spool	curve
1	1
2	4
3	3
6	3
81	1
51A, 51B	1
41A, 41B	2

The operating limits of the valve are determined at a voltage 10% below the nominal rating. The curves refer to application with symmetrical flow through the valve (P-A and B-T). In the case of asymetric flow (e.g. one part not used) reduced values may result.

Note: For valves with adjustment of the switching time reduced values of the operating limits may result.

Mechanically operated

Hydraulically operated

Electrically operated



Dimensions

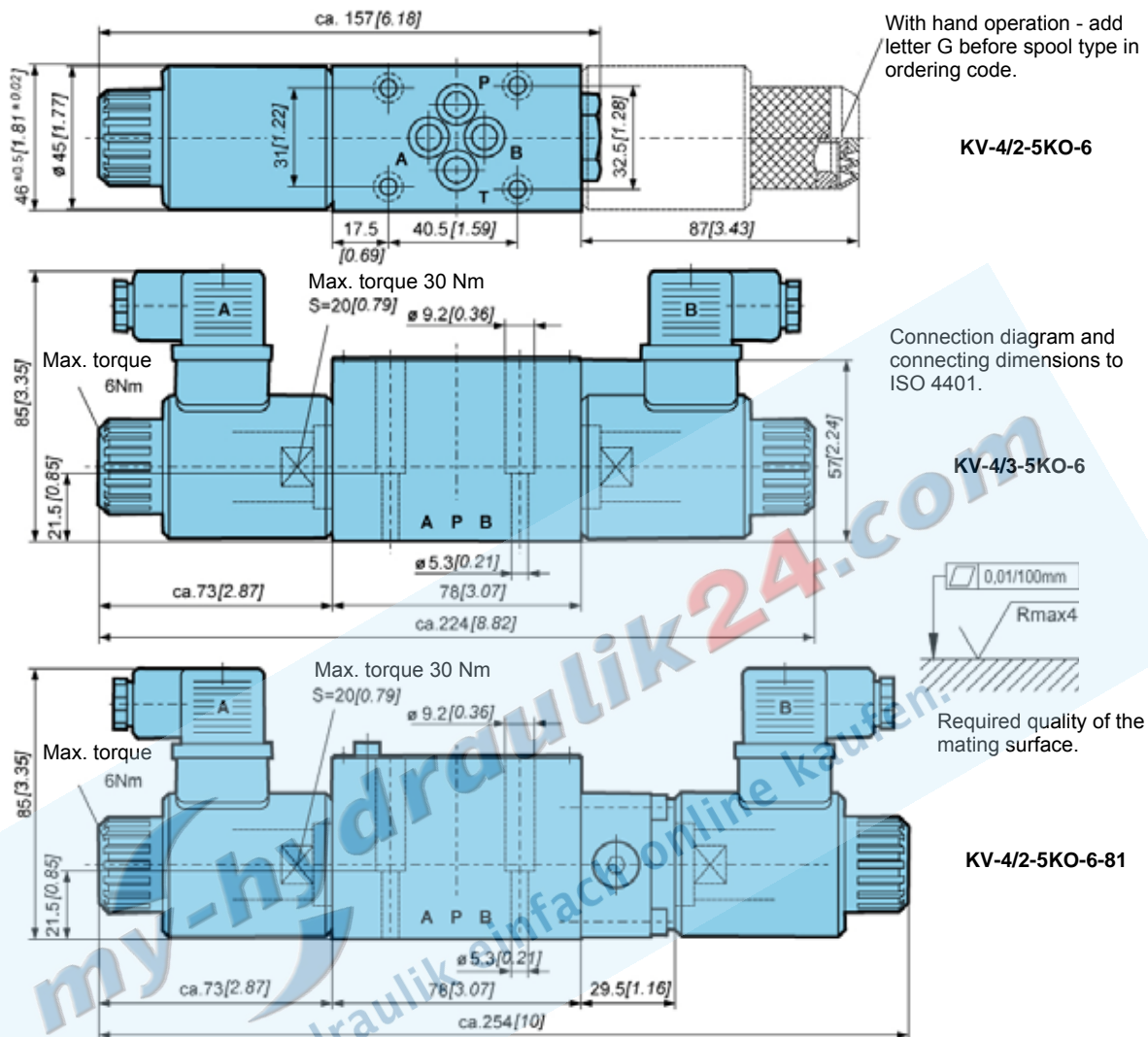

Cartridge throttle

If flow rates greater than permissible occur during change-over, a cartridge throttle must be fitted into P-line of the directional valve.

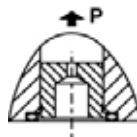

Installation

The directional control valve must be installed horizontally (Nameplate on top). If this is not the case, the valve must be removed for venting. Unscrew the vent screw. Move the spool alternately to the switching positions a and b until no more bubbles appear at the screw hole. The oil must be visible at the screw hole. Missing oil should be refilled with an oilcan, drop by drop. Screw in the vent screw.

A constant or short time static oil pressure of at least > 4 bar must prevail at connection T of the directional control valve to maintain the oil pressure in the spring chambers. If this is not the case, the preloaded oil volume of the restricted valve would leak into the T channel through the leakage section of the control spool shoulders.

The dampening constancy also depends on the constancy of the oil viscosity. For this reason the dampening effect should always be adjusted with the system at operational temperature.



Function drawing

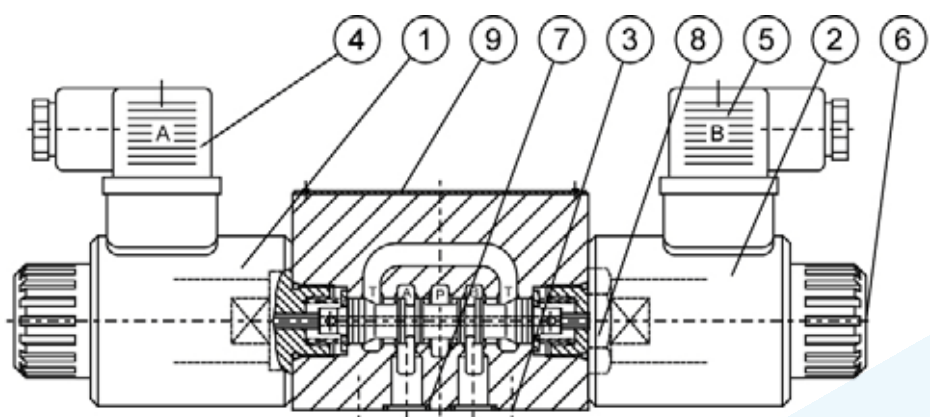

KV-4/3-5KO-6
(KV-4/2-5KO-6)

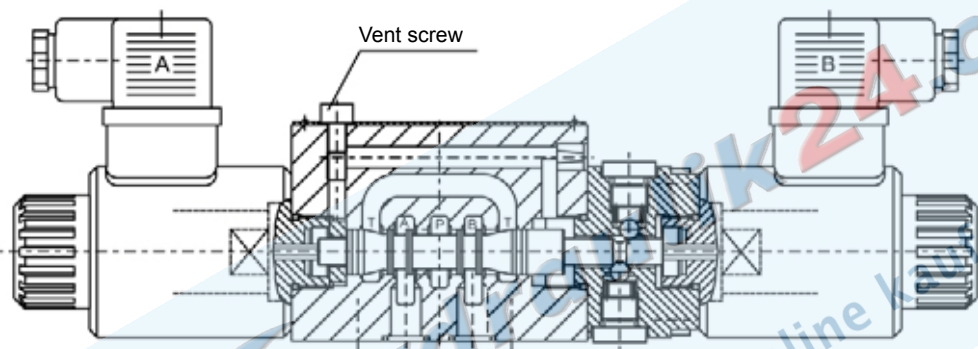

KV-4/2-5KO-6-81

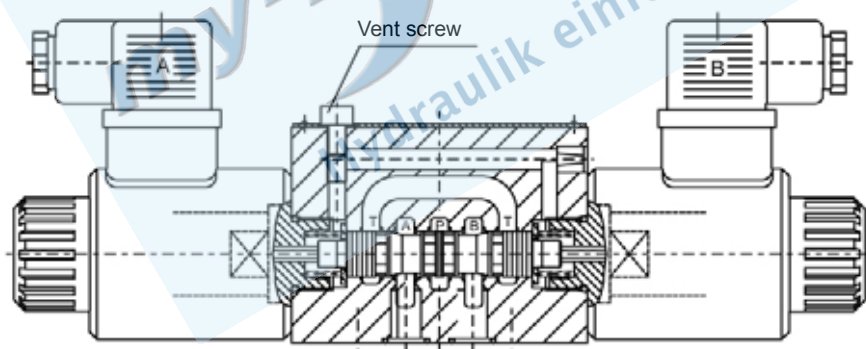

KV-4/3-5KO-6-2

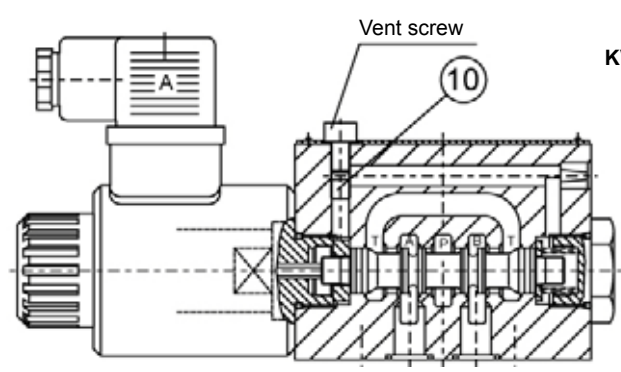

KV-4/2-5KO-6-UD

- 1. Solenoid "a" - MR-045
- 2. Solenoid "b" - MR-045
- 3. Fixing screws 4 pcs M5 x 30 to ISO 4762
-10.9 must be ordered separately.
Required tightening torque Md = 9 Nm
- 4. Plug-in connector "a" - grey
- 5. Plug-in connector "b" - black
- 6. Emergency manual override
- 7. O-ring 9,25 x 1,78
- 8. Valve cap
- 9. Nameplate
- 10. Constant action restrictor

Mechanically operated

Hydraulically operated

Electrically operated



Model code

K V - / - **5 K O** - **6** -

Working ports

Three working ports	3
Four working ports	4

Number of control spool positions

Two positions	2
Three positions	3

Manual override option

Emergency manual override	No designation
Manual override with rubber cover	G
Lockable manual override	C

Spool types

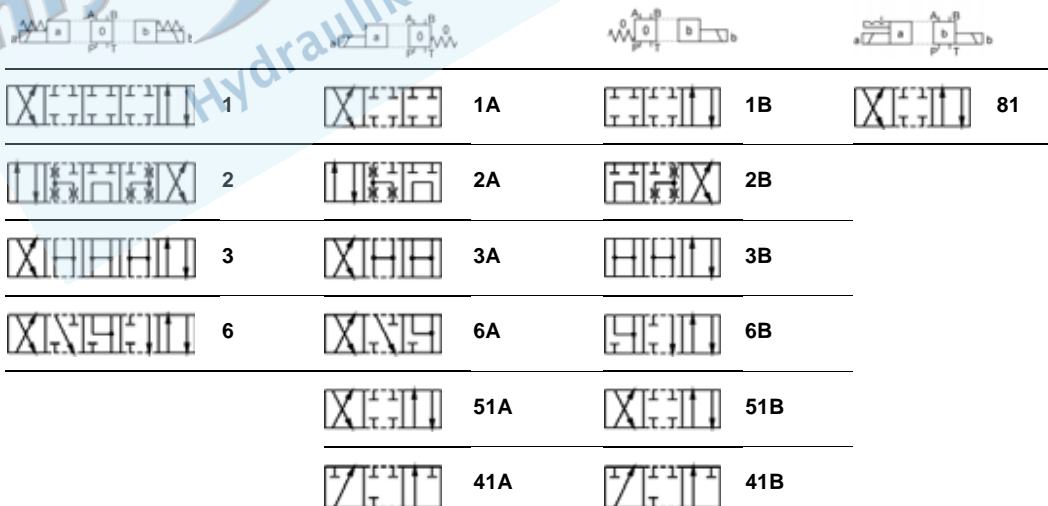

Port T in the valves with spool type 41A and 41B to be used as leakage line.



Valves with adjustment of the switching time - a constant or short - time static oil pressure of at least ≥ 4 bar [58 PSI] must prevail at connection T of the directional control valve to maintain the pressure in the spring chambers.

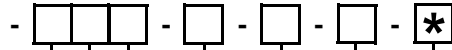

Supply voltage

	Direct voltage	Alternating voltage
12V	12DC	12AC
24V	No designation	24AC
48V	48DC	48AC
110V	110DC	110AC
230V	230DC	230AC*

- Alternating voltage solenoids are fitted with a bridge rectifier.
- With solenoids of over 48 V an earthing clamp to ISO 4400 must be connected.

*To fulfil EMC (89/336/EEC) a capacitor must be built in.

Connector type

EN 175301-803 without signal lamp	No designation
EN 175301-803 with signal lamp	L
EN 175301-803 without connector	K
AMP junior timer without connector	M
Deutsch	V

Overvoltage protection

Without overvoltage protection	No designation
With overvoltage protection	T

Throttle mm [in]

Without throttle in P line	No designation
Throttle Ø 0,8 [0.03 dia.]	D08
Throttle Ø 1,0 [0.04 dia.]	D10
Throttle Ø 1,2 [0.05 dia.]	D12

Constant action restrictor

Without restrictor	No designation
With restrictor Ø 0,35 [0.01 dia.]	UD

Seal type

NBR seals for mineral oil HL,HLP to DIN 51524	No designation
FPM seals for HETG, HEES, HEPG to VDMA 24568 and ISO 15380	E

Special requirements to be briefly specified

Mechanically operated

Hydraulically operated

Electrically operated

