

Features:

- For threaded connection (screw-in connection)
- Subplate mounting
- Leakage-free closure in one direction
- Various cracking pressures, optional (see ordering details)

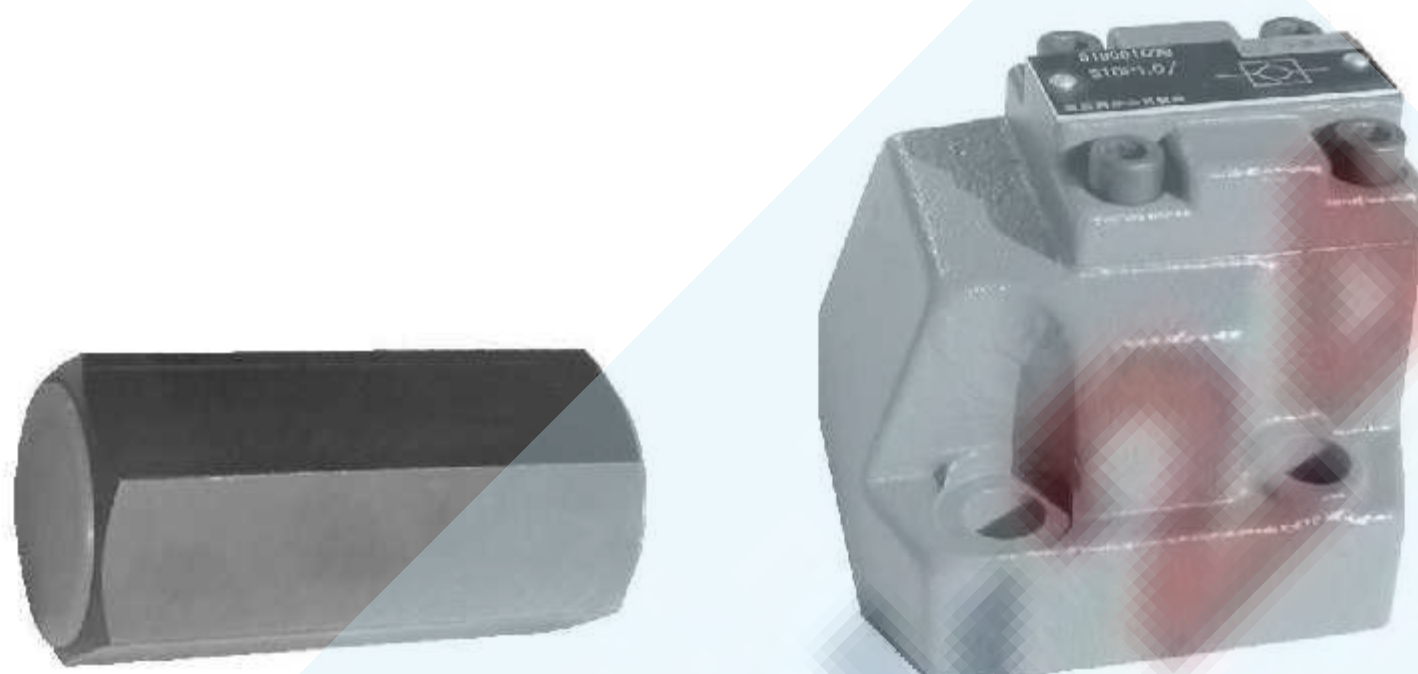

Function, section, symbols

The check valve type S has the task of, preferably closing a flow leak free in one direction and to permit free flow in the opposite direction. The stroke of the poppet, which is guided on its outside diameter, is limited by a mechanical stop. The built-in compression spring supports the closing movement. Furthermore the compression spring holds the poppet in the closed position even when there is no flow through the valve.

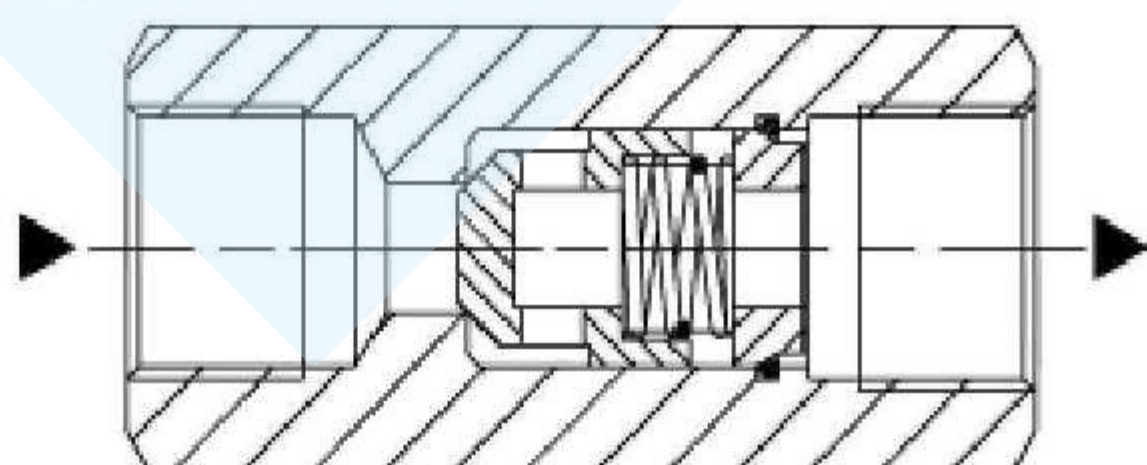

Threaded connection

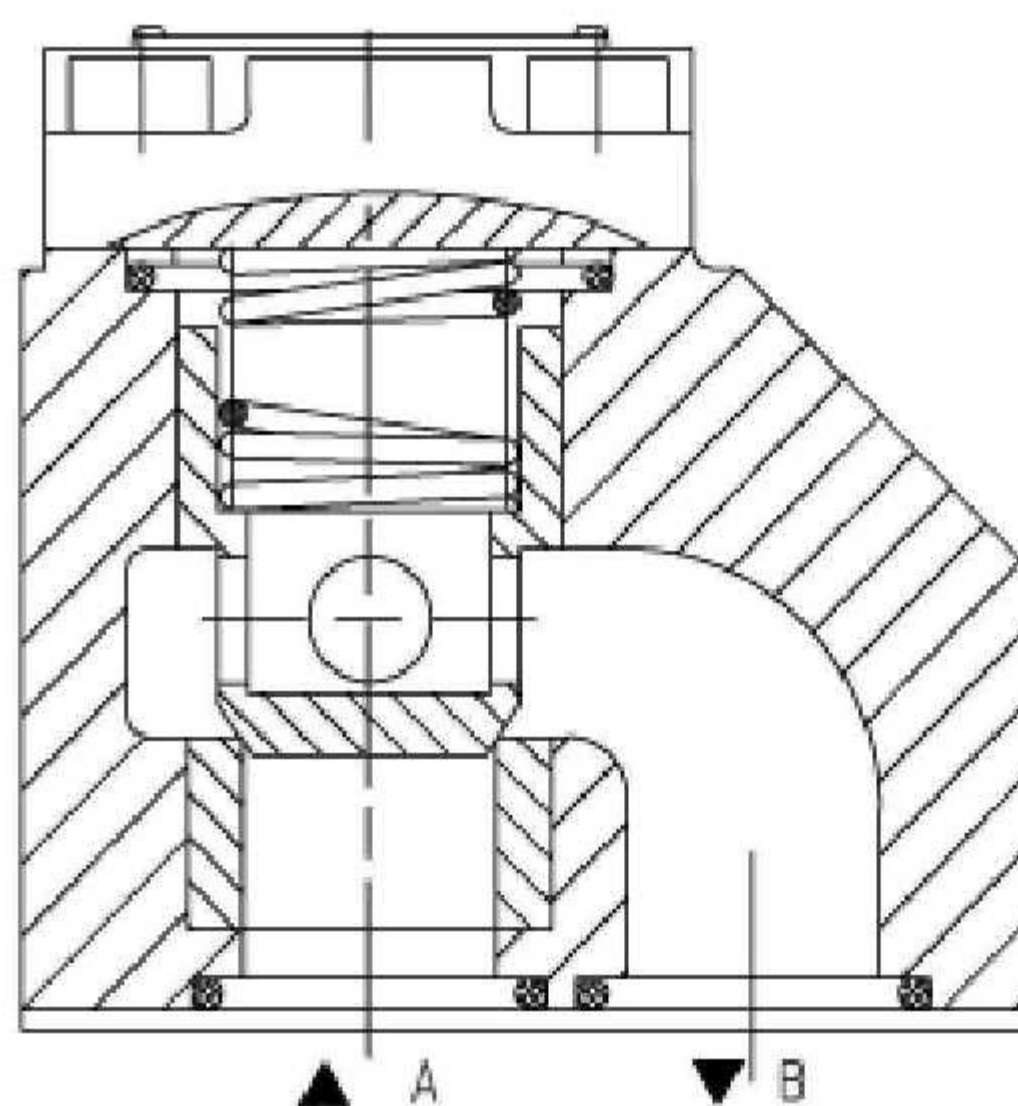

Subplate mounting

Technical data (For applications outside these parameters, please consult us!)

Pressure fluid		Mineral oils or phosphate ester
Pressure fluid - temperature range	(°C)	-30 ~ +80
Viscosity range	(mm ² /s)	2.8 ~ 500
Max. operating pressure	(MPa)	31.5
Cracking pressure	(MPa)	See characteristic curves below
Maximum flow	(L/min)	

Characteristic curves (measured at $\nu = 41 \text{ mm}^2/\text{s}$ and $t = 50^\circ\text{C}$)

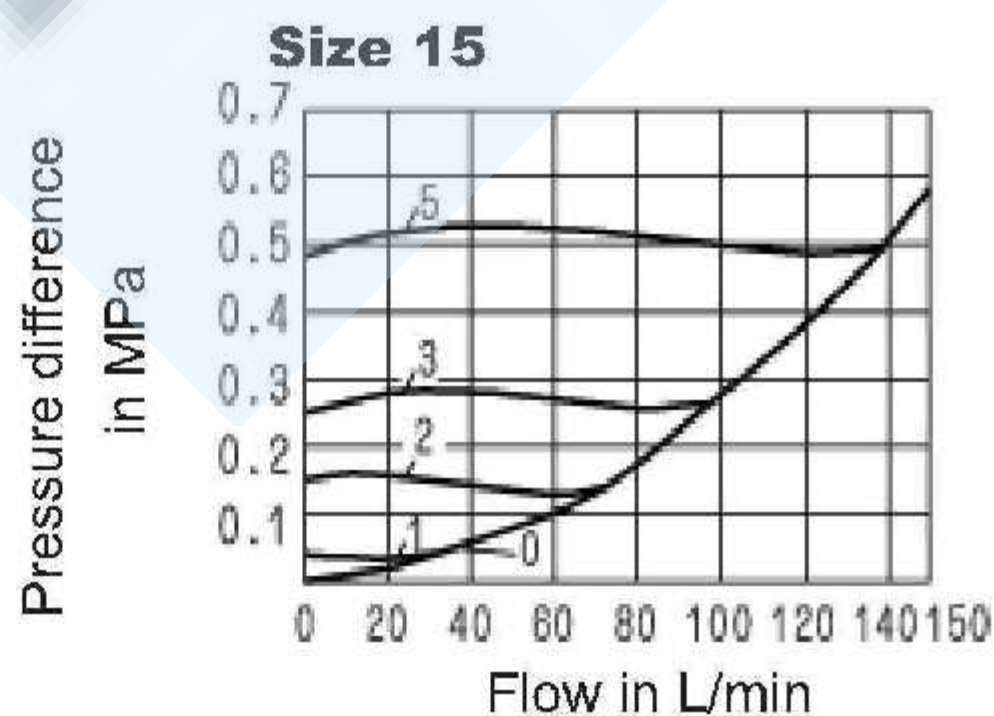
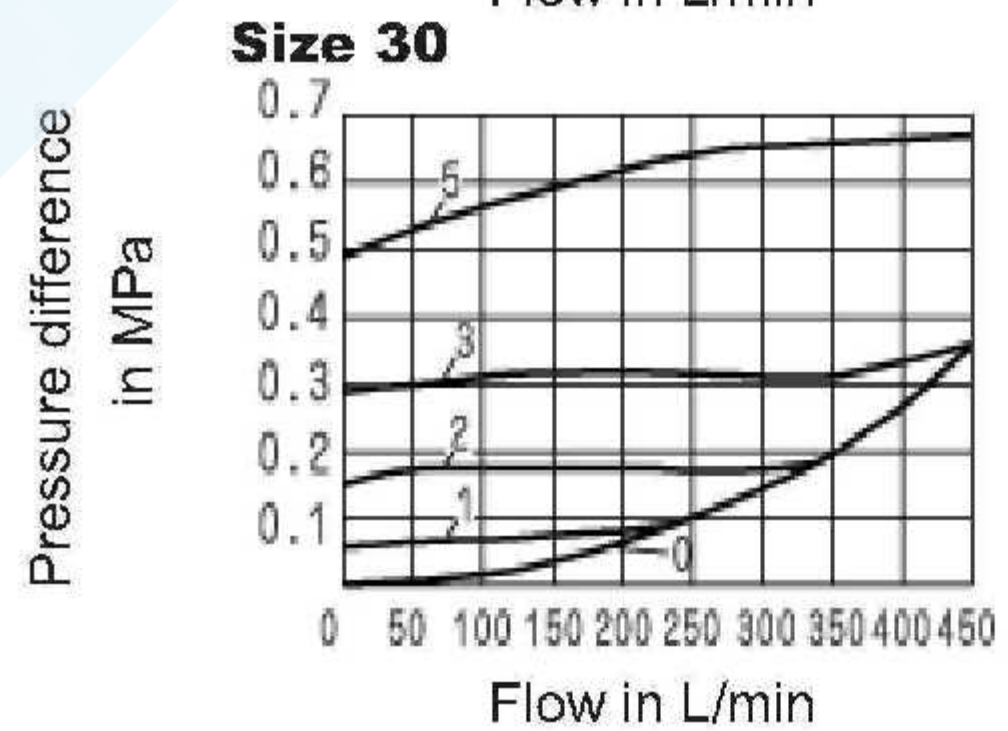
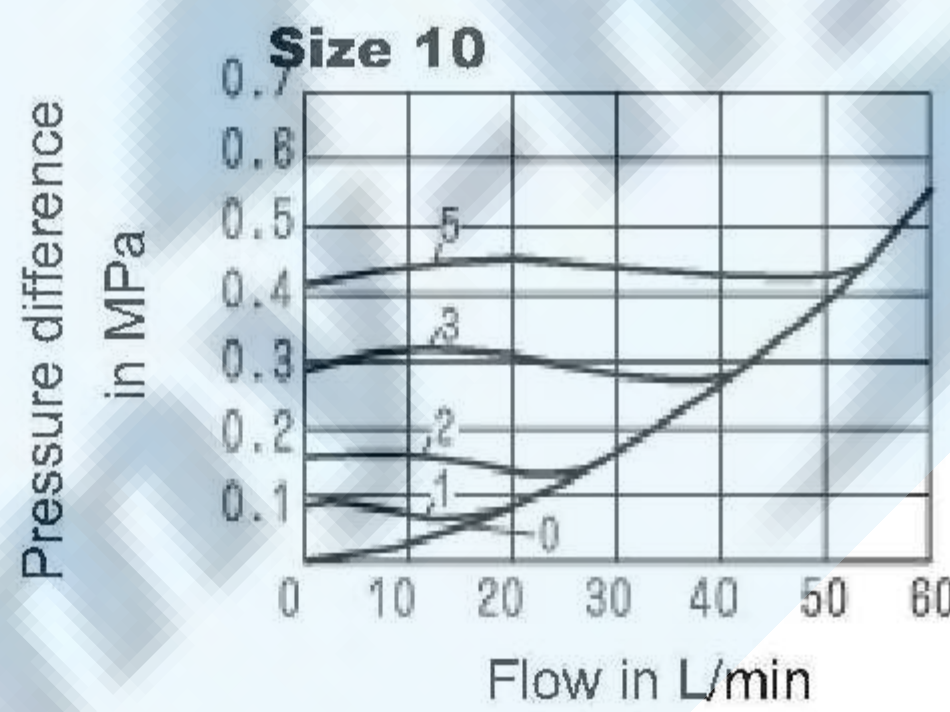
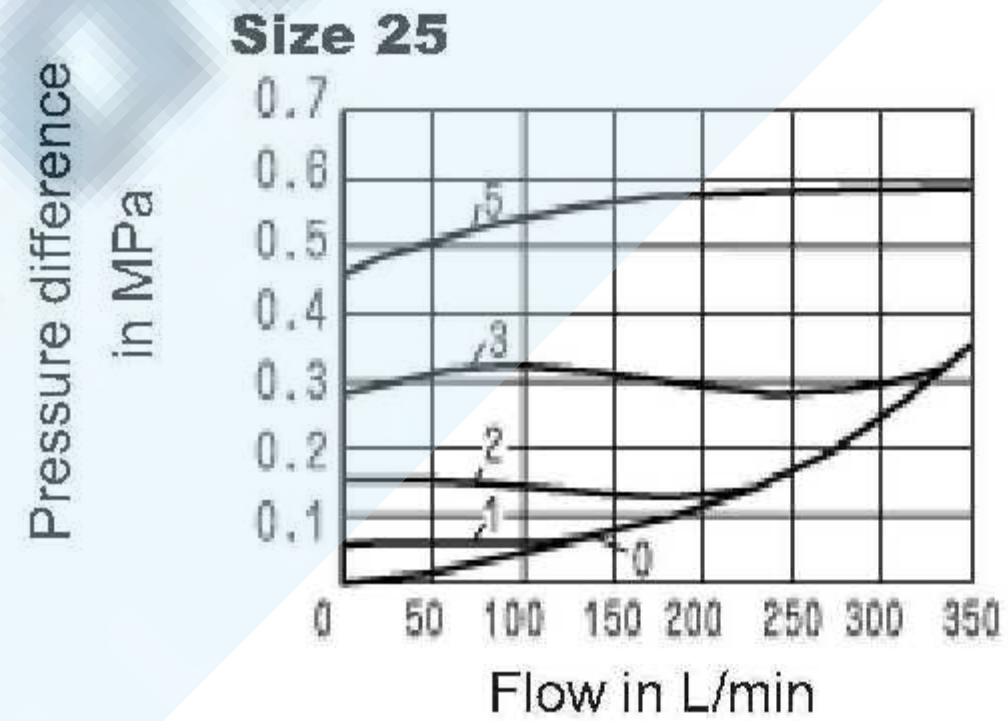
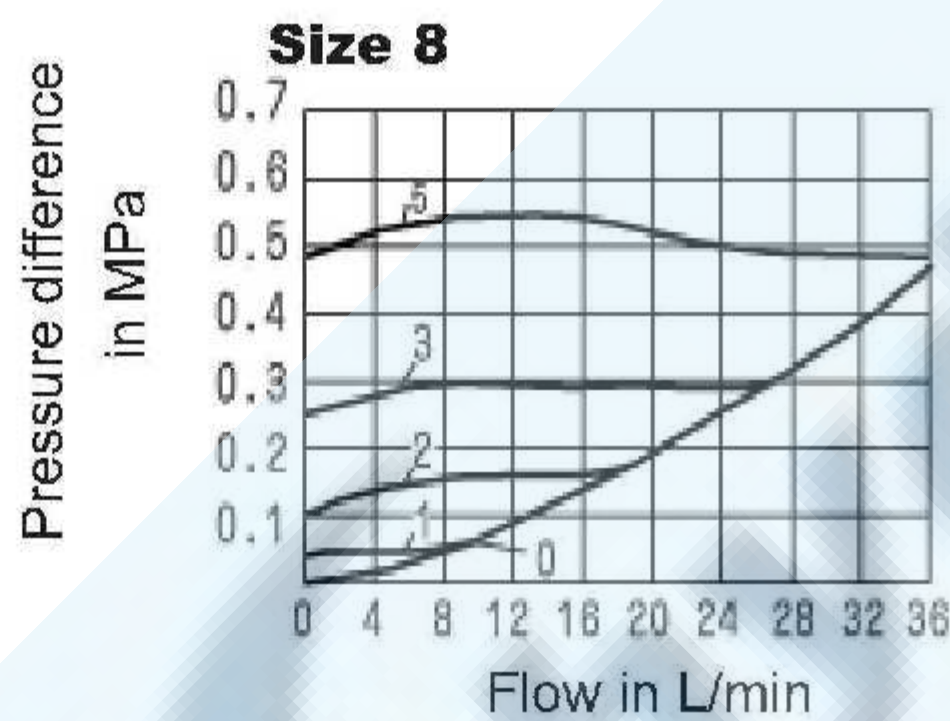
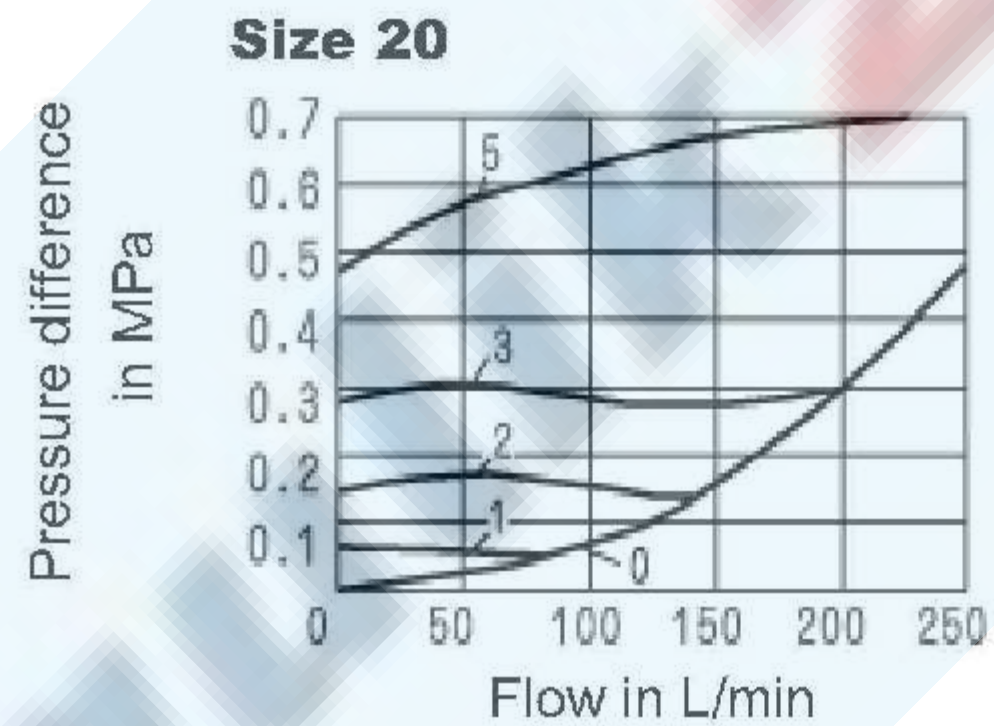
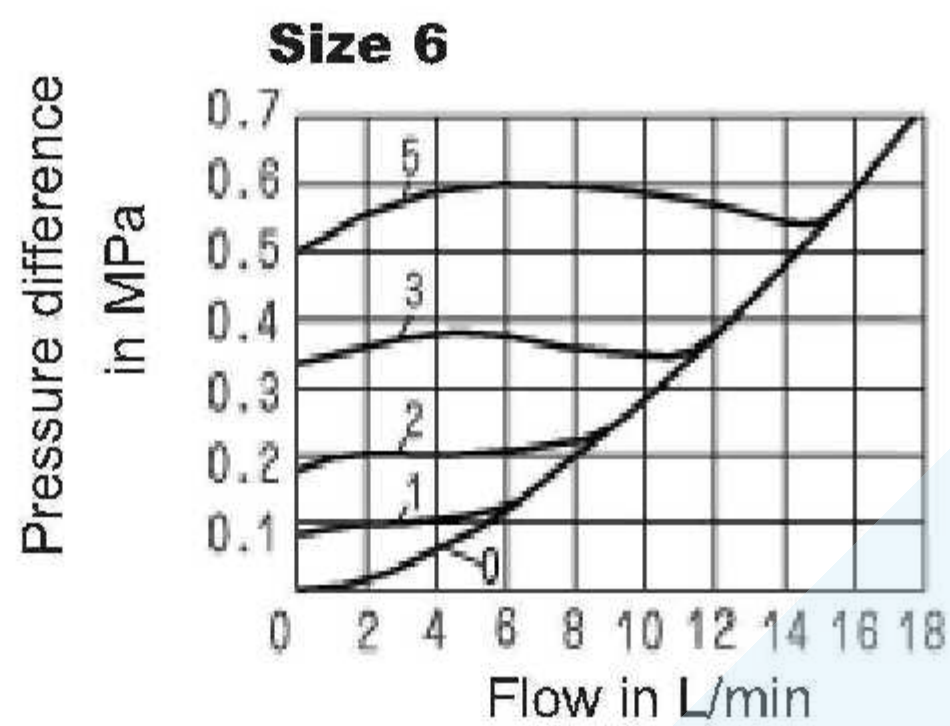

Pressure difference Δp related to the flow q_v at the cracking pressure

Unit dimensions

(Dimensions in mm)

Threaded connection:

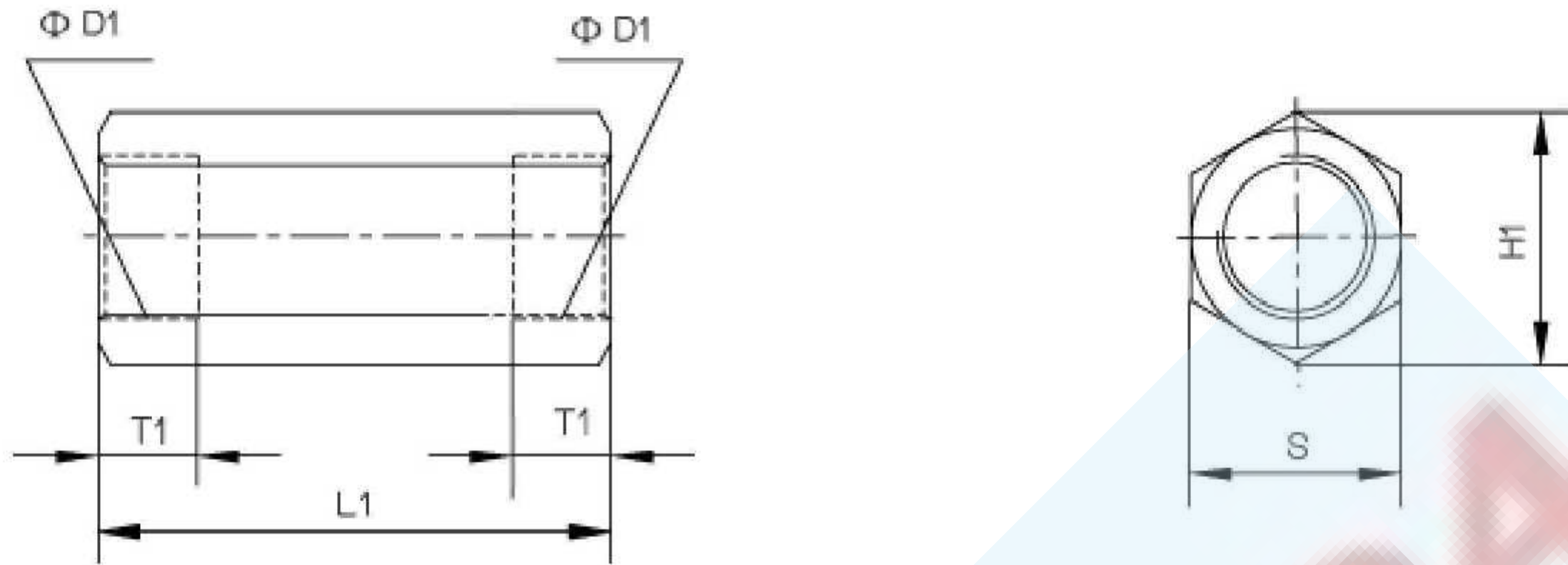

Size	6	8	10	15	20	25	30
D1	G1/4"	G3/8"	G1/2"	G3/4"	G1"	G1 1/4"	G1 1/2"
	M14X1.5	M18X1.5	M22X1.5	M27X2	M33X2	M42X2	M48X2
H1	22	28	34.5	41.5	53	69	75
L1	58	58	72	85	98	120	132
T1	12	12	14	16	18	20	22
S	19	24	30	36	46	60	65
Weight (K g)	0.1	0.2	0.3	0.5	1	2	2.5

Valve cartridge

Straight-angled check valve

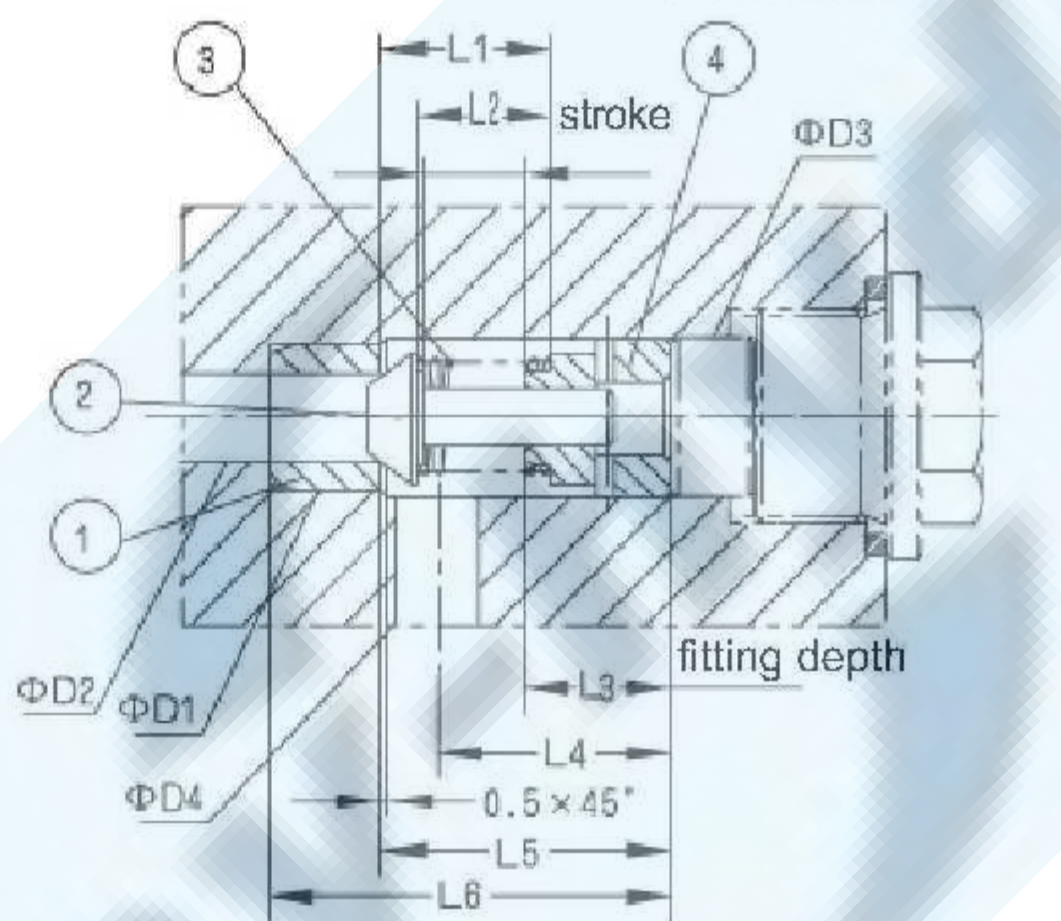

NG	6	8	10	15	20	25	30
Φ D1H7	10	13	17	22	28	36	42
Φ D2	6	8	10	15	20	25	30
Φ D3H8	11	14	18	24	30	38	44
Φ D4	6	8	10	15	20	25	30
Journey	4	4	4	5	5	7	7
L1	11.2	11.9	14.3	18	18.8	28.5	28.5
L2	9.5	9.5	11.5	14.5	16	24.5	25
L3	10	16	16	18	23	31	37
L4	16.5	21.5	23.5	25.5	30	43	47.5
L5	20.5	26.5	29.5	34	40.5	57.5	63.5
L6	28.5	36.5	39.5	46	55.5	75.5	83.5
Weight	0.05Kg	0.05Kg	0.05Kg	0.1Kg	0.2Kg	0.25Kg	0.3Kg

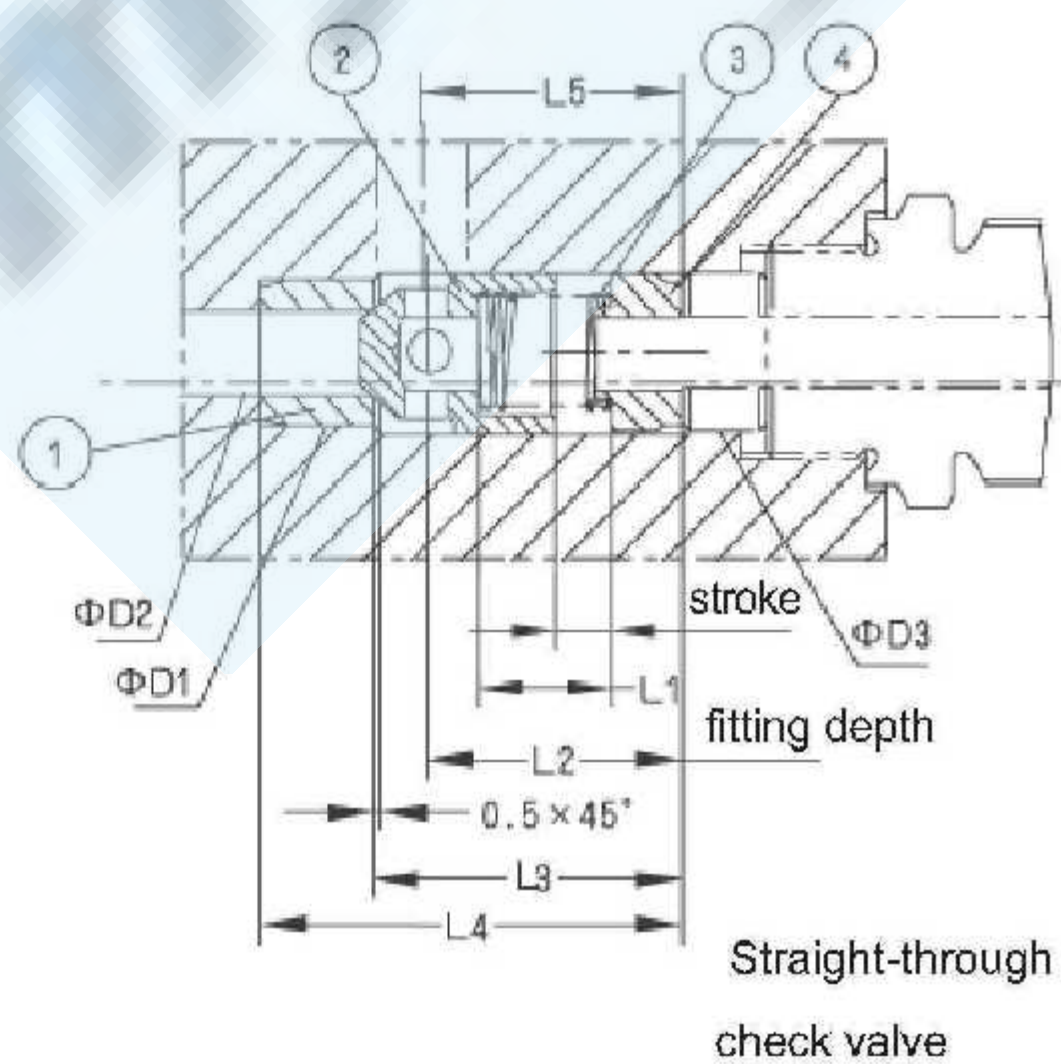

NG	6	8	10	15	20	25	30
Φ D1H7	10	13	17	22	28	36	42
Φ D2	6	8	10	15	20	25	30
Φ D3H8	11	14	18	24	30	38	44
Journey	4	4	4	5	5	7	7
L1	9.5	9.5	11.5	14.5	16	24.5	25
L2	19	18	21	27	29	29	42
L3	21.8	22.8	28.8	36.4	44	55	63
L4	29.8	32.8	38.8	48.4	59	73	83
L5	18	18	23	28	33	41	47
Weight	0.05Kg	0.05Kg	0.05Kg	0.1Kg	0.2Kg	0.25Kg	0.3Kg

Unit Dimensions

(Dimensions in mm)

Subplate mounting:

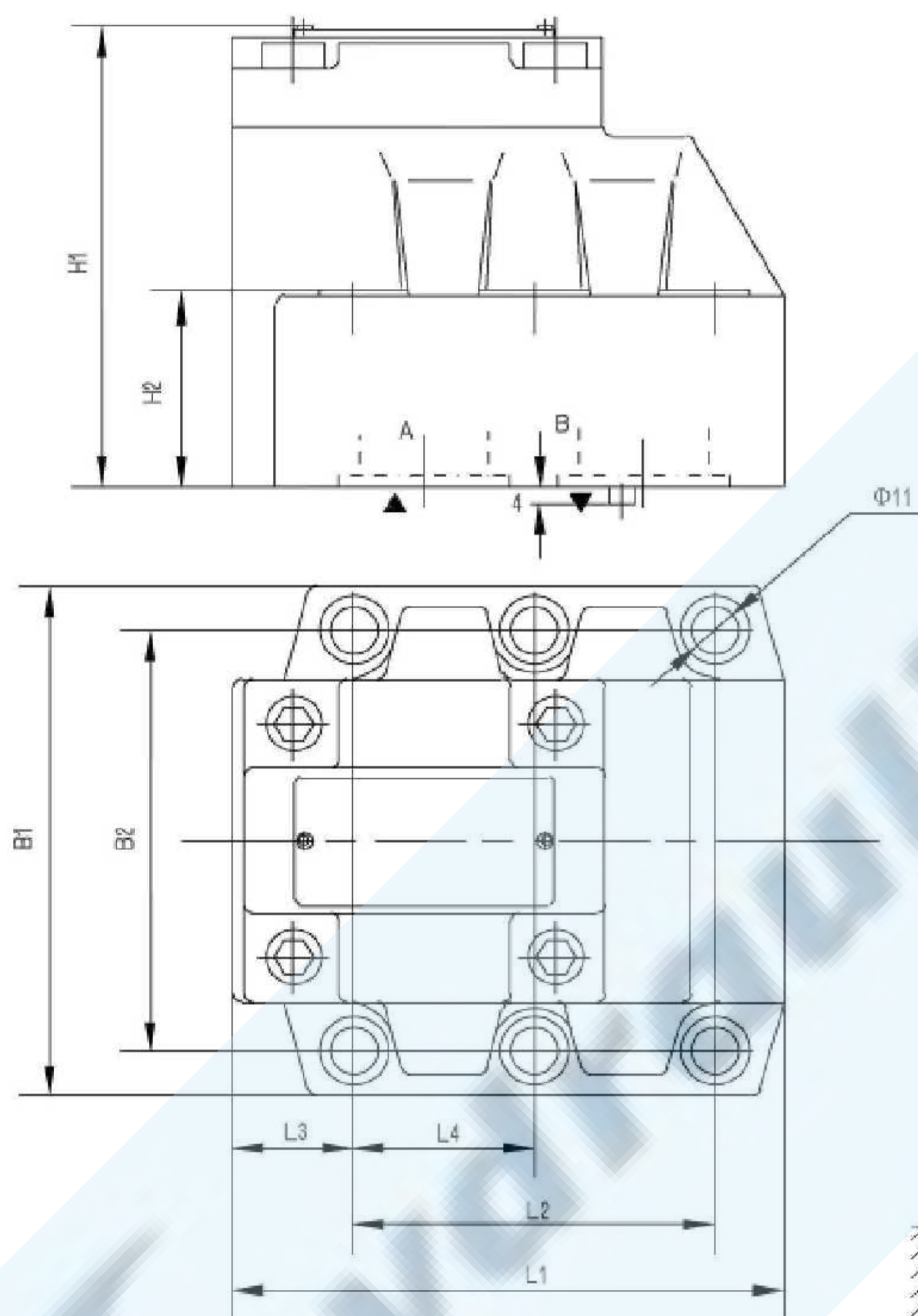

Required surface finish of mating piece

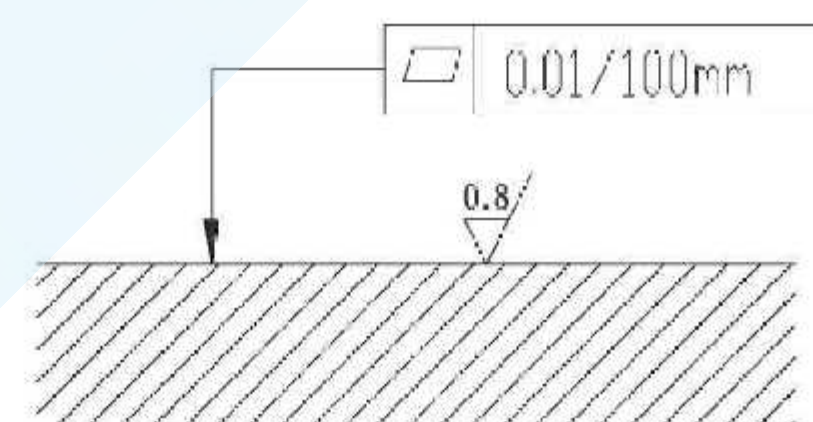

Subplate : NG10 :

G460/01 G460/02
G461/01 G461/02

NG20 :

G412/01 G412/02
G413/01 G413/02

NG30 :

G414/01 G414/02
G415/01 G415/02

must be ordered separately, see page 204

Size	The valve fixing screws (GB/T70.1-2000)	Ports A,B O-ring
10	4-M10 × 40 -10.9	17.12 × 2.62
20	4-M10 × 50 -10.9	28.17 × 3.53
30	4-M10 × 70-10.9	34.52 × 3.53

NG	B1	B2	L1	L2	L3	L4	H1	H2
10	85	66.7	78	42.9	17.8	-	66	21
20	102	79.4	101	60.3	23	-	93.5	31.5
30	120	96.8	128	84.2	28	42.1	106.5	46

Notice

1. The fluid must be filtered. Minimum filter fineness is 20 μm .
2. The tank must be sealing up and an air filter must be installed on air entrance.
3. Products without subplate when leaving factory, if need them, please ordering specially.
4. Valve fixing screws must be high intensity level (class 10.9). Please select and use them according to the parameter listed in the sample book.
5. Roughness of surface linked with the valve is required to $\frac{0.8}{\nabla}$.
6. Surface finish of mating piece is required to 0.01/100mm.