

Features:

- Sandwich plate valve
- Porting pattern to DIN 24 340 form A, ISO 4401 and CETOP-RP 121 H
- For limiting the main or pilot fluid flow of 2 service ports
- 3 adjustment elements:
 - Lockable rotary knob with scale
 - Spindle with internal hexagon and scale
 - Rotary knob with scale
- For meter-in or meter-out control



Function , section

Valve type Z2FS 10...-30B/...is a double throttle/check valve in sandwich plate design.

It is used to limit the main or pilot flow of one or two service ports. Two symmetrically arranged throttle/check valves limit the flow in one direction and allow free-flow in the opposite direction. For meter-in control fluid passes from port A1 to port A2 via the throttling point (1), which is made up to the valve seat (2) and the throttling spool (3.1). The throttling spool (3.1) is axially adjustable via the spindle (4), thus allowing the throttling point (1) to be adjusted. At the same time the fluid in port A1 reaches spool side (6) via bore (5). The pressure present in addition to the spring force holds the throttle spool (3.1) in its throttling position. Flow flowing back from the service port B2 moves the throttle spool (3.2) against the spring (7) causing the valve to act as a check valve and allowing free-flow. Depending upon the way in which the valve is installed, the throttling effect can be arranged as a meter-in or meter-out control.

Limiting the main fluid flow

In order to change the velocity of an actuator (main fluid flow), the double throttle/check valve is installed between the directional valve and the sub-plate.

Limiting the pilot fluid flow

In pilot operated directional control valves, the double/throttle check valve is installed as a pilot choke adjustment (pilot fluid flow). It is fitted between the main valve and the pilot valve.

Type Z2FS 10 -5-30B/...

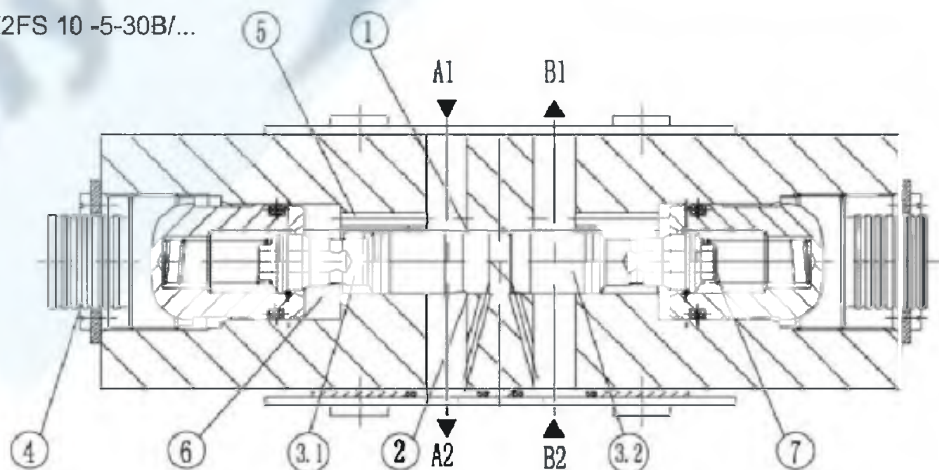

Ordering details

Z2FS 10 30 *

Double throttle/check valve

Further details in clear text

Nominal size 10 = 10

No code = Mineral oil
V = Phosphate ester

Throttle/check valve ports A and B = -
Throttle/check valve port A = A
Throttle/check valve port B = B

No code = (With two throttle/check valves) Meter-in /meter-out throttling, (this valve can be turned)
S = (...A.-30B/S) meter-in on port A (...B.-30/S) meter-in on port B
S2 = (...A.-30B/S2) meter-out on port A (...B.-30/S2) meter-out on port B
S3 = (...A.-30B/S3) meter-out on port A (...B.-30/S3) meter-in on port B
S4 = (...A.-30B/S4) meter-in on port A (...B.-30/S4) meter-in out port B

Adjustment element
Lockable rotary knob with scale = 3
Spindle with internal hexagon and scale = 5
Rotary knob with scale = 7

Series 30 to 39 =30
(30 to 39: unchanged installation and connection dimensions)

Note: Type Z2FS 10-...-30B/..has the same adjustment elements on ports A and B!

Symbols (① = valve side, ② = sub-plate)

Z2FS10-...-30B/..(meter-in)

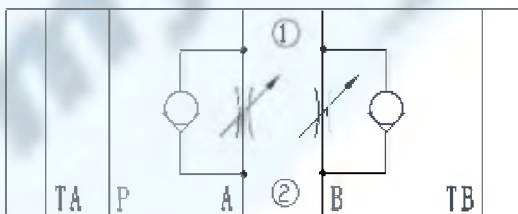

Z2FS10-...-30B/..(meter-out)

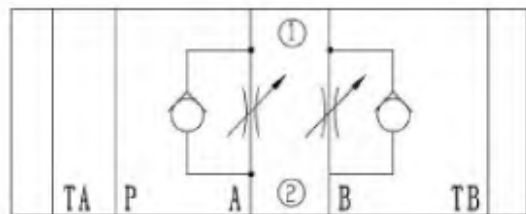

Symbols (① = valve side, ② = sub-plate)

Z2FS10-...-30B/S3..(port A meter- out,
port B meter-in)

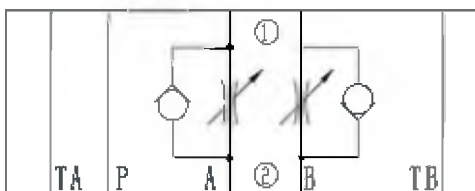

Z2FS10-...-30B/S4..(port A meter-in,port B
meter-out)

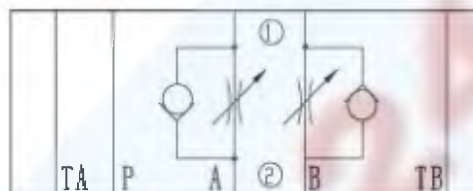

Z2FS10A-...-30B/S..(port A meter-in)

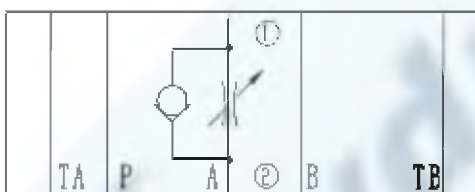

Z2FS10B-...-30B/S..(port B meter-in)

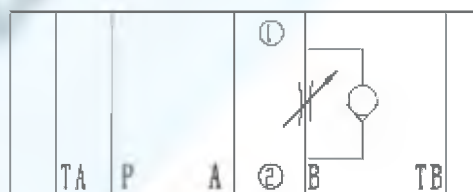

Z2FS10A-...-30B/S2..(port A meter-out)

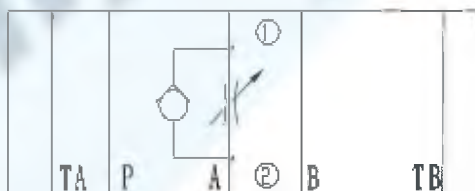

Z2FS10B-...-30B/S2..(port B meter-out)

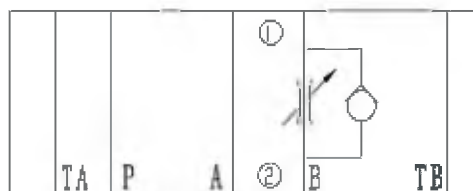

Technical data (for applications outside these parameters, please consult us!)

Pressure fluid	Mineral oil(for NBR seal) or Phosphate ester (for FPM seal)	
Pressure fluid temperature range	(°C)	- 30 to + 80
Viscosity range	(mm ² / s)	10 to 800
Degree of contamination	Maximum permissible degree of contamination of the hydraulic fluid to NAS 1638 class 9. We therefore recommend a filter with a minimum retention rate of $\beta_{10} \geq 75$.	
Maximum working pressure	(MPa)	up to 31.5
Maximum flow	(L/min)	up to 160
Weight	(kg)	approx.3.1

Characteristic curves (measured at $v = 41 \text{ mm}^2/\text{s}$ and $t = 50^\circ\text{C}$)

Pressure difference Δp in relation to the flow q_v at constant throttle setting

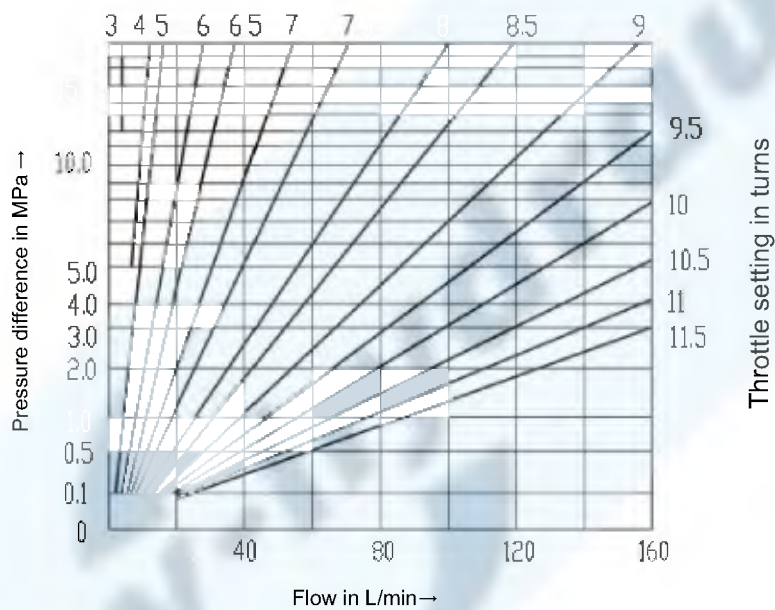

Pressure difference Δp in relation to the flow q_v across the check valve

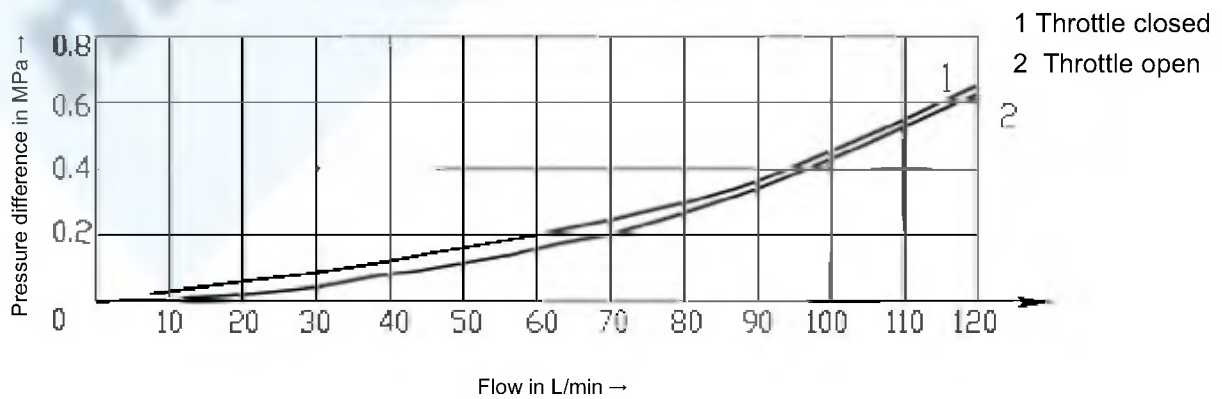

Type Z2FS 10...-30B/

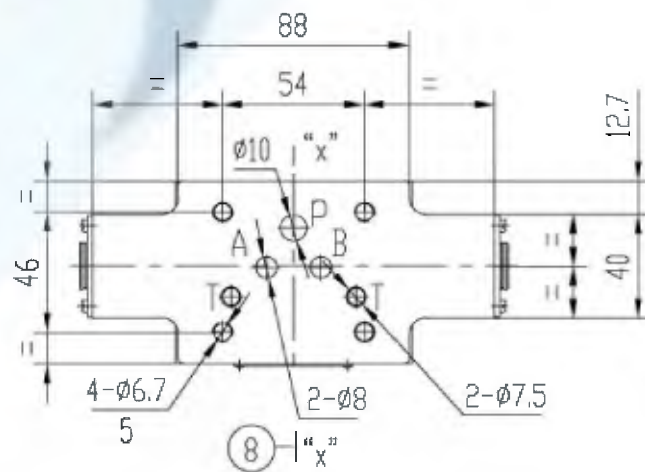
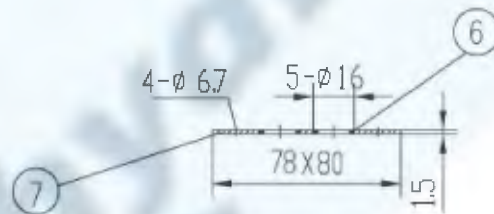
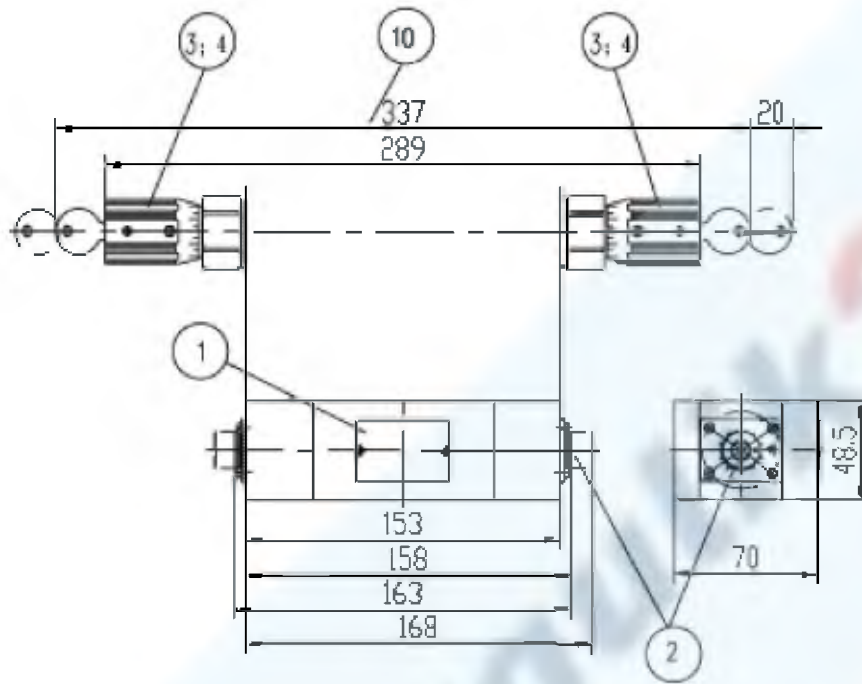

Unit dimensions

(Dimensions in mm)

Type Z2FS10 A.. - 30B/

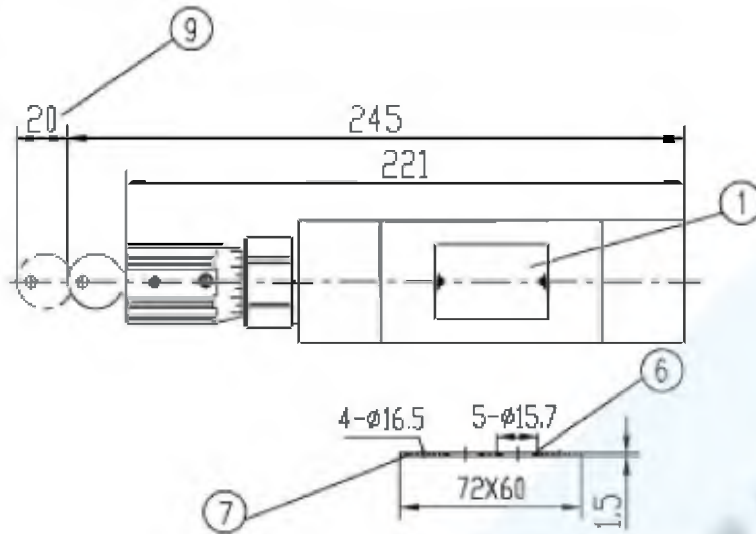

Type Z2FS10 B.. - 30B/

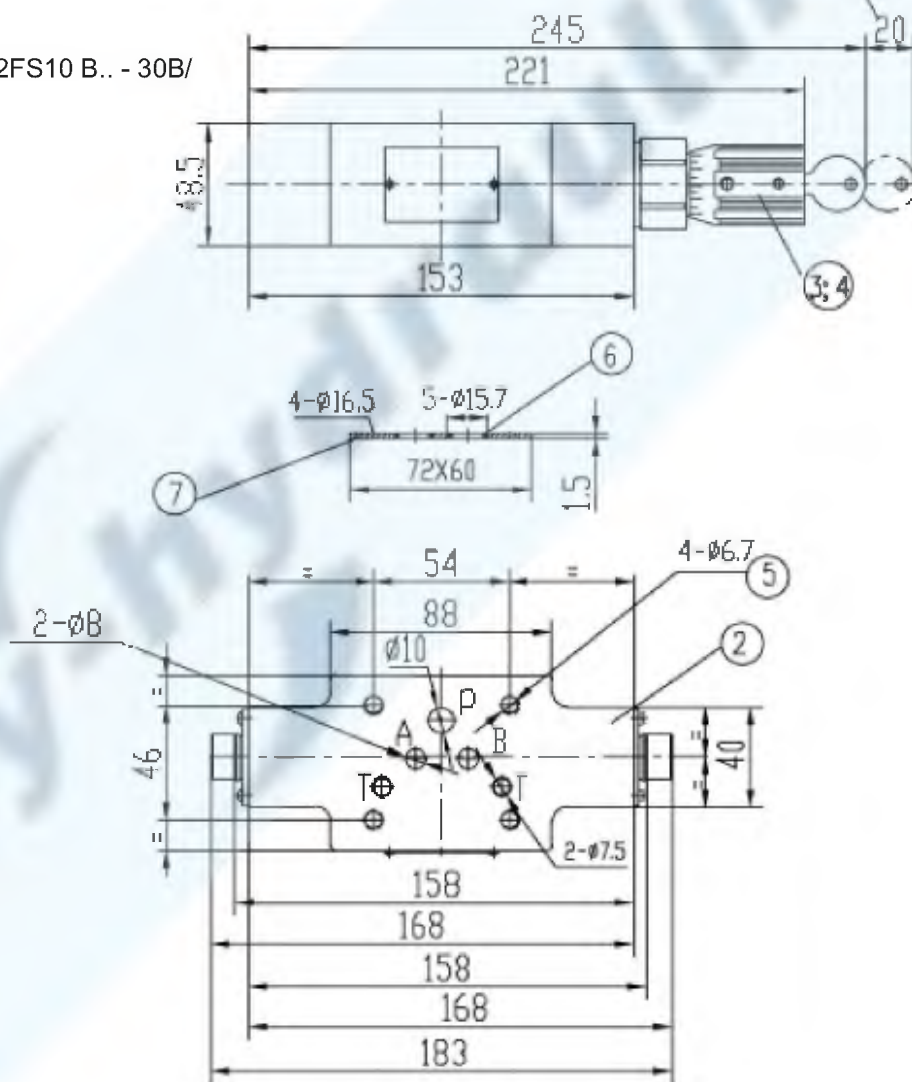

- 1 Nameplate
- 2 Adjustment "5"
- 3 Adjustment "3"
- 4 Adjustment "7"
- 5 4 through holes for valve fixing screws
- 6 O-ring 9.25x1.78 for ports A, B, P, TA, TB
- 7 O-ring plate
- 8 To change from meter-in to meter-out, rotate the unit about the "X"- "X" axis
- 9 Space required to remove key
- 10 Only for adjustment "7"

Valve fixing screws
M5 -10.9 (GB/T70.1-2000)
Tightening torque $M_A = 15.5 \text{ Nm}$.

Required surface finish of
mating piece

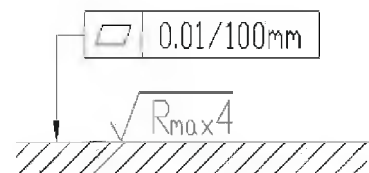

Notice

1. The fluid must be filtered. Minimum filter fineness is 20 μm .
2. The tank must be sealing up and an air filter must be installed on air entrance.
3. Products without subplate when leaving factory, if need them, please ordering specially.
4. Valve fixing screws must be high intensity level (class 10.9). Please select and use them according to the parameter listed in the sample book.
5. Roughness of surface linked with the valve is required to $\sqrt{0.8}$.
6. Surface finish of mating piece is required to 0.01/100mm.